

GC32907A

Grinding AUTO REST®

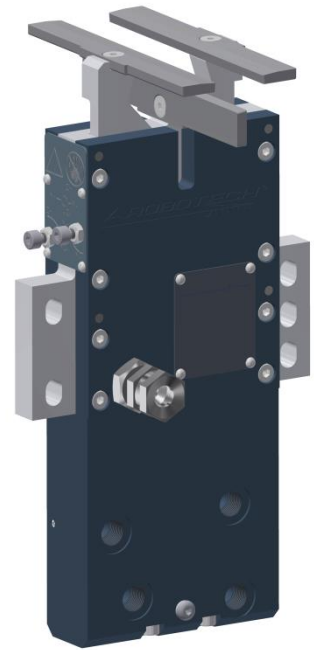
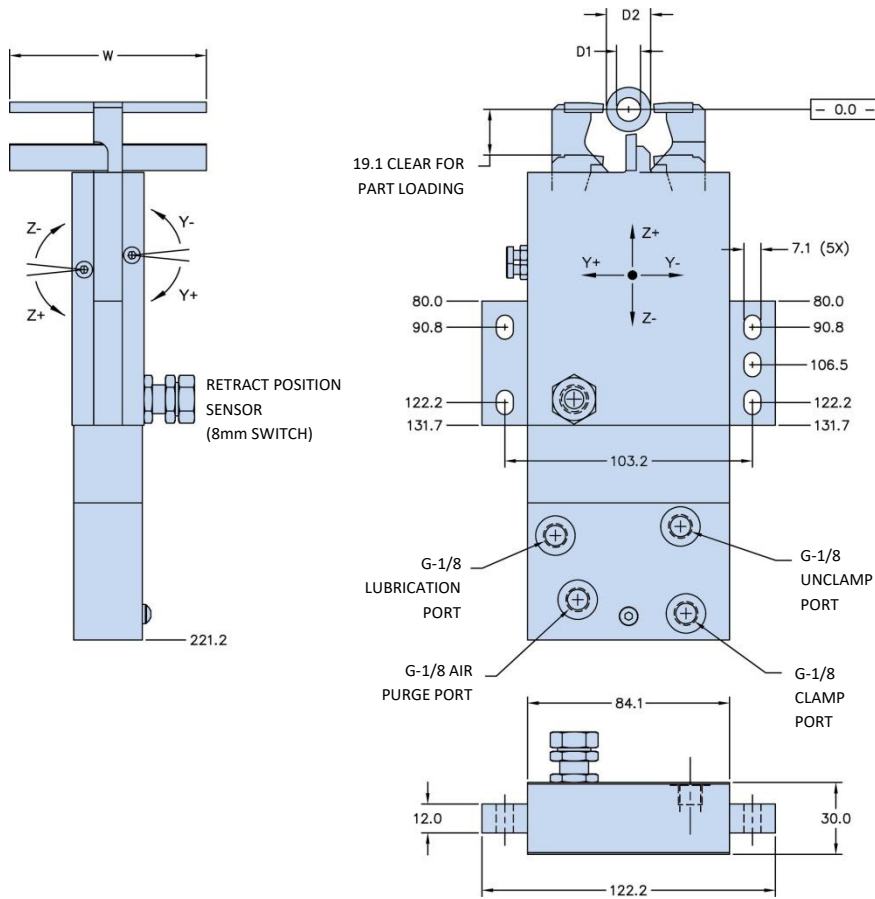

Pad Set			2	3	4	5	6	7	8	9	10	11
Minimum Clamp Diameter	D1	mm	2	3	3	3	3	3	10	10	10	18.5
Maximum Clamp Diameter	D2	mm	4	10	10	10	10	10	18.5	18.5	18.5	26.5
Width	W	mm	50	10	15	25	45	82	40	70	108	170

Z-Axis Adjustment Range	mm	±0.13
Y-Axis Adjustment Range	mm	±0.08
Piston Area	cm ²	2.8
Cylinder Stroke	mm	29
Operating Pressure	bar	10 – 27
Maximum Pressure	bar	32
Air Purge Pressure	bar	0.3 – 0.5
Lubrication Volume	cm ³	0.02 – 0.03
Lubrication Frequency		Working Cycle (or every 6 minutes)
Repeatability	mm	±0.001
Mass	kg	4

** Contact sales@arobotech.com for pads not listed above

Included Features

- * Arm Retraction For Part Loading
- * 2-Axis Centerline Adjustment
- * Retract Position Feedback Sensor
- * Air Purge Port

Items Required To Use

- This Product:
- * Set of Wear Pads
 - * Mounting Base